

T-650 Mini Trigger

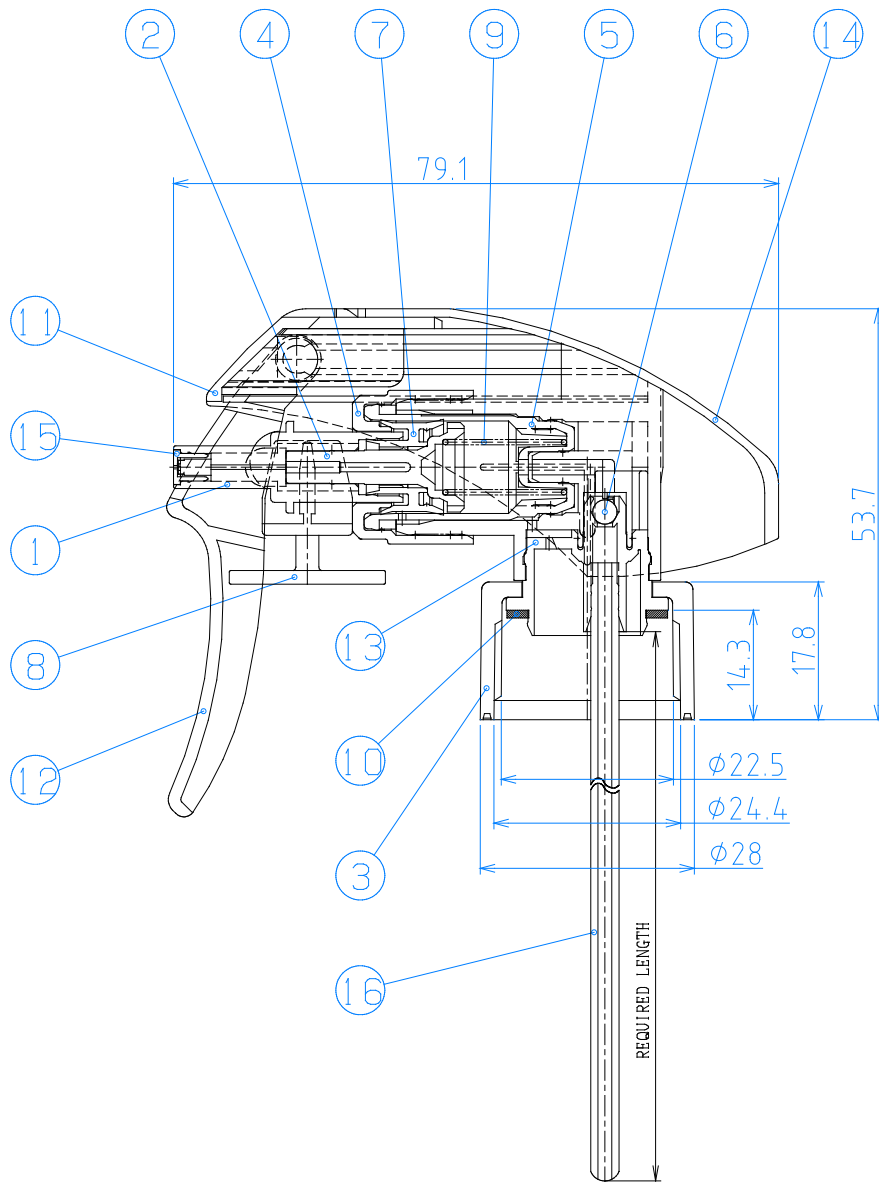

No.	Name	Dwg No.	Material	Remarks
1	PISTON (1)	T650- 401- 2- 0	HDPE	NATURAL
2	PISTON (2)	T650- 402- 1- 0	PP	NATURAL
3	CLOSURE CAP	T305- 503-38- 0	PP	NATURAL
4	CYLINDER(1)	T650- 601- 1- 0	PP	NATURAL
5	CYLINDER(2)	T650- 602- 1- 0	PP	NATURAL
6	BALL	90- 702	SUS	OUTER DIAMETER=φ3.18
7	PISTON SEAL	T650- 801-36- 0	LDPE	NATURAL
8	STOPPER	T650- 901-38-200	PP	BLUE (PPD 10563 B)
9	SPRING	T650-1001	SUS	WIRE DIAMETER=φ0.7
10	GASKET	T305-1303-10- 1	FOAMED PE, PP LAMINATED	BLUE t=1.0
11	TRIGGER BASE	T305-1702-38- 0	PP	NATURAL
12	TRIGGER	T305-3201-38- 0	PP	NATURAL
13	INTAKE	T305-4202-46- 0	POM	NATURAL
14	BODY	T305-4303-38- 0	PP	NATURAL
15	NOZZLE	ND- 37- 0	POM	NATURAL
16	DIP-TUBE	SD- 75	LDPE	φ3.65xφ2.4 REQUIRED LENGTH